

# BURTON JAMES

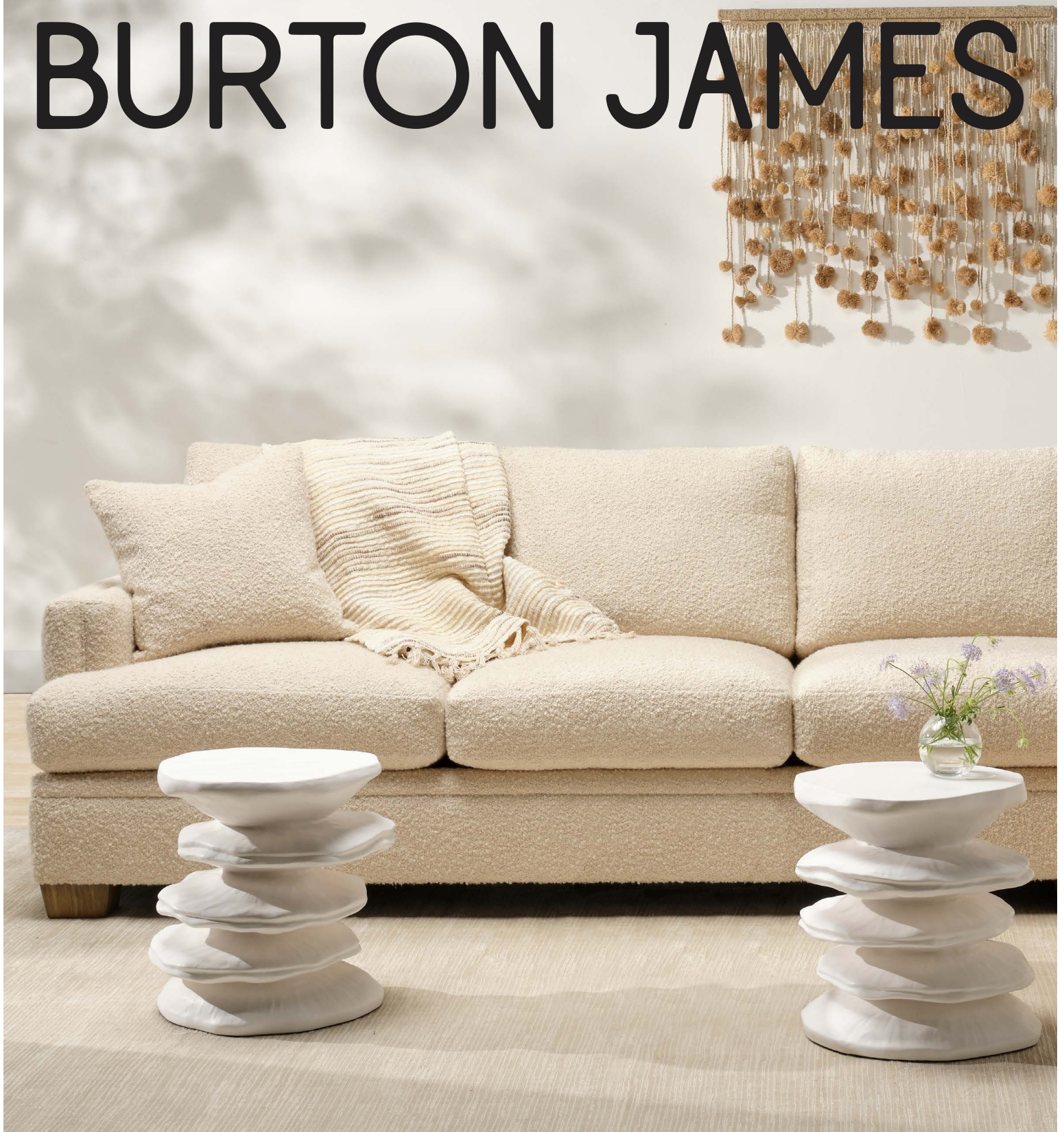

# ALTERNATIVES

PERFECT COMFORT FOR EVERY STYLE



PERFECTLY STYLISH,  
PERFECTLY COMFORTABLE,  
**PERFECTLY**  
**YOU**

Our **ALTERNATIVES** program, widely acclaimed as our most popular program among designers, distinguishes itself by offering the widest array of configurations, along with the option to select your depth and height.

Featuring a selection of arm styles, base and leg options, and back and seat cushion styles, **ALTERNATIVES** offers you the ability to create the spaces you dream of.

For questions, more information, or to request a custom quote, contact your sales representative or visit [BURTONJAMES.COM](http://BURTONJAMES.COM).



## STANDARD FEATURES

- Cloud 9 Seat Cushions
- Blend Down Back Cushions
- 8 Gauge Sinuous Springs
- Solid Kiln-Dried Wood Frame
- 20×20 Throw Pillows Included with Most Configurations
- All Pieces Available In:
  - Overall Depths: 36", 38", and 40"
  - Overall Back Heights: 34", 36", and 38"
  - Seat Cushions: 27"W
    - #10 Chair Cushion is 23"W
    - #22 Small Sofa Cushion is 30"W

## STEP 1: CHOOSE YOUR STYLE, DEPTH, AND HEIGHT

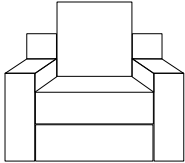
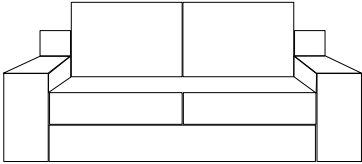
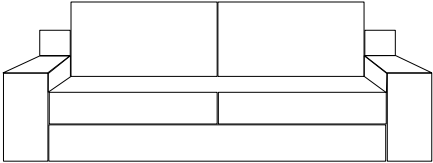
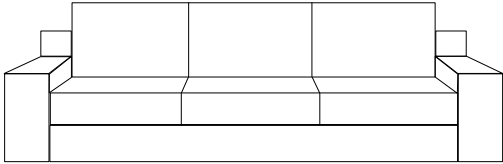
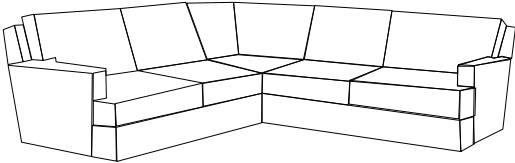
STYLE	OVERALL DEPTH	OVERALL HEIGHT
 <input type="checkbox"/> #10 - 23" Chair + Arms <input type="checkbox"/> Swivel Base (Upcharge)	<input type="checkbox"/> 36" (20" Seat Depth) <input type="checkbox"/> 38" (22" Seat Depth) <input type="checkbox"/> 40" (24" Seat Depth)	<input type="checkbox"/> 34" <input type="checkbox"/> 36" <input type="checkbox"/> 38"
 <input type="checkbox"/> #20 - 54" Loveseat + Arms	<input type="checkbox"/> 36" (20" Seat Depth) <input type="checkbox"/> 38" (22" Seat Depth) <input type="checkbox"/> 40" (24" Seat Depth)	<input type="checkbox"/> 34" <input type="checkbox"/> 36" <input type="checkbox"/> 38"
 <input type="checkbox"/> #22 - 60" Small Sofa + Arms	<input type="checkbox"/> 36" (20" Seat Depth) <input type="checkbox"/> 38" (22" Seat Depth) <input type="checkbox"/> 40" (24" Seat Depth)	<input type="checkbox"/> 34" <input type="checkbox"/> 36" <input type="checkbox"/> 38"
 <input type="checkbox"/> #30 - 81" Sofa + Arms	<input type="checkbox"/> 36" (20" Seat Depth) <input type="checkbox"/> 38" (22" Seat Depth) <input type="checkbox"/> 40" (24" Seat Depth)	<input type="checkbox"/> 34" <input type="checkbox"/> 36" <input type="checkbox"/> 38"
 <input type="checkbox"/> Sectional	<p align="center"><b>SELECT SECTIONAL PIECES AT STEP 8.</b></p> <p align="center">Options are only enabled if "sectional" is selected.</p>	

## STEP 2: CHOOSE YOUR ARM

Select welting options at step 7. Contrast welting subject to upcharge.

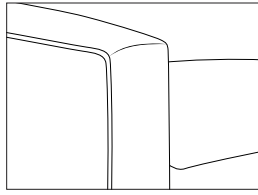

**4" Track Arm**

24"H

NO WELT

WELTING

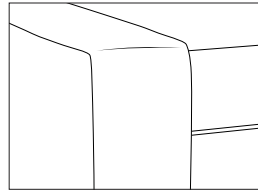

**6" Track Arm**

24"H

NO WELT

WELTING

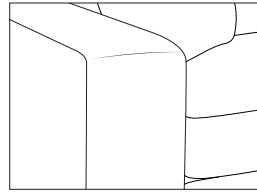

**9" Track Arm**

24"H

NO WELT

WELTING

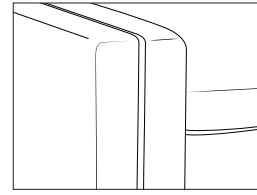

**6" Split Track**

26"H

INCLUDES 1/4" STANDARD WELT

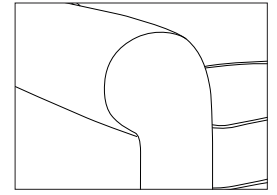

**8" Sock Arm**

26"H

NO WELT

WELTING

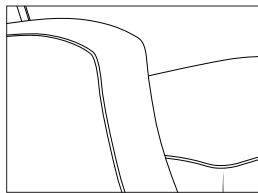

**4.5" Deco Arm**

24"H

NO WELT

WELTING

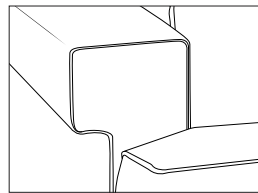

**6" Grand Arm**

24"H

NO WELT

WELTING

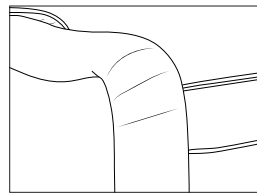

**6" English Arm**

26"H

NO WELT

WELTING

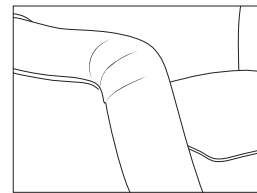

**6" Bentley Arm**

24"H

NO WELT

WELTING

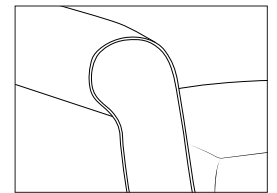

**6" Dorset Arm**

24"H

NO WELT

WELTING

## STEP 3: CHOOSE YOUR BASE

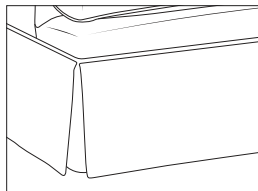

**T-Flounce**  
Hidden Leg\*

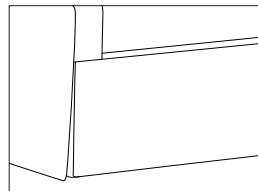

**S-Flounce**  
Hidden Leg\*

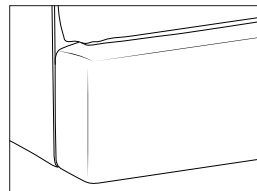

**Plain**  
Hidden Leg\*

**Plain**  
Exposed Leg\*\*

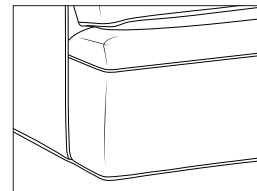

**Banded**  
Hidden Leg\*

**Banded**  
Exposed Leg\*\*

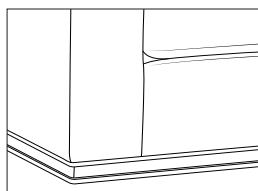

**Molded Wood Base**  
**UPCHARGE**

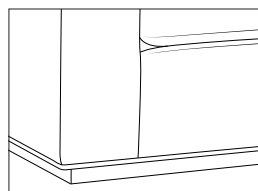

**Recessed Wood Plinth Base**  
**UPCHARGE**

\*Hidden leg finish is Caramel.

\*\*Choose leg and wood finish at step 7. Base is shortened proportionally to exposed leg height.

## STEP 4: CHOOSE YOUR SEAT SHAPE & SEAT FILL

Select welting options at step 7. Contrast welting subject to upcharge.

### SEAT SHAPE

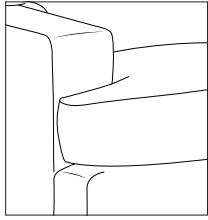

**T-Cushion**

NO WELT

WELTING

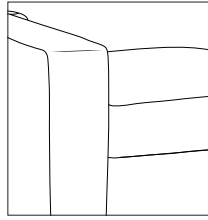

**Square Cushion**

NO WELT

WELTING

### SEAT FILL

**Cloud 9 (Standard Fill)**

High density foam core, wrapped in two layers of polyester fiber for softness and bounce, encased in ticking for strength and durability. This is our most popular seat cushion.

**Luxe Aire (No Additional Charge)**

Premium polyurethane foam wrapped in D91 polyester fiber and encased in ticking. This is a firm seat with minimum crown ensuring comfort and durability.

**Down Supreme (Upcharge)**

High density foam interior encased in a 100% cotton down proof ticking envelope, of 90% feather and 10% down.

**Spring Down (Upcharge)**

High density foam interior surrounding a spring system, encased in a 100% cotton down proof ticking envelope, of 90% feather and 10% down.

**Trillum (Upcharge)**

High density foam core, encased in a 100% blown polyester fiber filled 100% cotton, channeled down proof cover. This option creates a very plush cushion that has a down like quality.



## STEP 5: CHOOSE YOUR BACK SHAPE & BACK FILL

Select welting options at step 7. Contrast welting subject to upcharge.

### BACK SHAPE

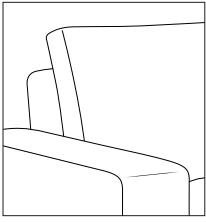

**Square Boxed**

NO WELT

WELTING

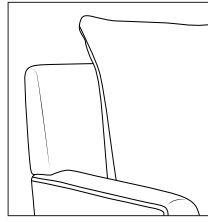

**Knife Edge**

NO WELT

WELTING

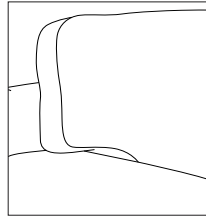

**T-Boxed**

NO WELT

WELTING

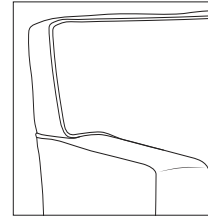

**Tight Boxed**

NO WELT

WELTING

### BACK FILL

**Blend Down (Standard Fill)**

50% blown poly fiber, 45% feather, and 5% down channeled in a 100% cotton down proof ticking. This is our most popular back cushion.

**Regalaire (No Additional Charge)**

Polyester fiber channeled inside a nonwoven casing. This choice offers a firm but soft back cushion that requires some fluffing.

**Down Supreme (Upcharge)**

90% feather, 10% down channeled in a 100% cotton down proof ticking.

**Trillium (Upcharge)**

100% blown polyester fiber encased in a 100% cotton, channeled down proof cover. This soft, plush back cushion has a down like quality.

## STEP 6: CHOOSE YOUR FABRIC

Any fabric from our Burton James collection, or COM, can be used. Refer to price list for pricing.

PATTERN: \_\_\_\_\_

COLOR: \_\_\_\_\_

## STEP 7: ADD YOUR FINISHING TOUCHES

Select additional options: exposed legs, wood leg/base finish, nailheads, and welting.

### EXPOSED LEG SHOWN IN CARAMEL

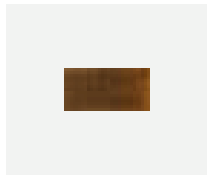

A - Wood  
5"W x 2"H



B - Wood  
6.5"W x 2"H



D - Wood  
5.75"W x 3"H



E - Wood  
5.75"W x 3"H



F - Wood  
6"W x 3"H



H - Wood  
2.75"W x 3.5"H



J - Wood  
3"W x 6"H



L - Wood  
3"W x 6"H



K - Acrylic  
3.5"W x 5.5"H

**UPCHARGE**

### CASTERS

- None       Hidden

### WOOD LEG AND BASE FINISH PICK ONE | HIDDEN LEG FINISH IS CARAMEL

#### Standard Wood Finishes



CREAM



MILK



CLOUD



NATURAL



SANDALWOOD



CARAMEL



FRENCH  
WALNUT



OLD OAK



UMBER



DRIFTWOOD



SHADOW



BLACK WALNUT

#### Premium Wood Finishes UPCHARGE



LINEN



PEARL



SAND



ASH



PUTTY



SLATE



SHALE



CAVALIER

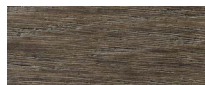

RUSTIC GRAY



REGENT



ZEBRA





BLACK  
LACQUER









**NAILHEADS UPCHARGE** | STANDARD DOES NOT INCLUDE NAILHEADS



**Nailhead Size** SHOWN TO SCALE | PICK ONE

- None
 
 Small: 7/16"
 
 Medium: 5/8"
 
 Large: 1"

**Nailhead Finish** 7/16" SHOWN | PICK ONE

- FRENCH NATURAL 
 PEWTER 
 NICKEL 
 BRIGHT GOLD 
 ANTIQUE BRASS 
 BLACK PEARL 
 BRONZE 

**Nailhead Spacing**

- HEAD-TO-HEAD 
  
 ONE ON, ONE OFF 

**Nailhead Location**

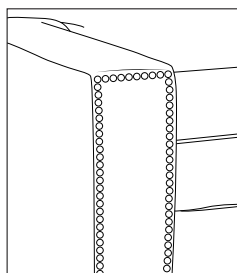
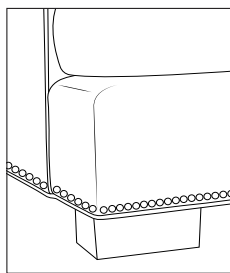
- ARMS 
 BODY/BASE 

**WELTING**

**Welt Location + Type**

**BODY**

- NONE  
 1/4" SELF WELT  
 1/8" SELF WELT  
 1/4" CONTRAST WELT  
**UPCHARGE**  
 1/8" CONTRAST WELT  
**UPCHARGE**

**ARM**

- 1/4" SELF WELT  
 1/8" SELF WELT  
 1/4" CONTRAST WELT  
**UPCHARGE**  
 1/8" CONTRAST WELT  
**UPCHARGE**

**SEAT CUSHION**

- 1/4" SELF WELT  
 1/8" SELF WELT  
 1/4" CONTRAST WELT  
**UPCHARGE**  
 1/8" CONTRAST WELT  
**UPCHARGE**

**BACK CUSHION**

- 1/4" SELF WELT  
 1/8" SELF WELT  
 1/4" CONTRAST WELT  
**UPCHARGE**  
 1/8" CONTRAST WELT  
**UPCHARGE**

CONTRAST WELT FABRIC PATTERN: \_\_\_\_\_

CONTRAST WELT FABRIC COLOR: \_\_\_\_\_

Images are representations only. For true match please refer to physical samples.  
 Premium finishes, nailheads & acrylic leg(s) subject to additional charge.

# STEP 8: CHOOSE YOUR SECTIONAL PIECES

Options are only enabled if "sectional" is selected at step 1 (page 4).

## OVERALL DEPTH

- 36" (20" Seat Depth)
- 38" (22" Seat Depth)
- 40" (24" Seat Depth)

## OVERALL HEIGHT

- 34"
- 36"
- 38"

**KEY:** ARMS BACK

THROW PILLOW

## SOFAS/CHAIR

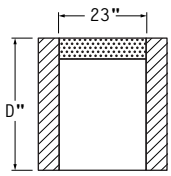

**#10**  
**CHAIR**  
23" + ARMS

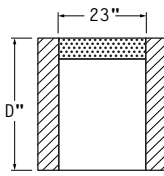

**#11**  
**SWIVEL CHAIR**  
23" + ARMS

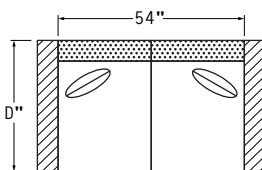

**#20**  
**54" LOVESEAT**  
54" + ARMS

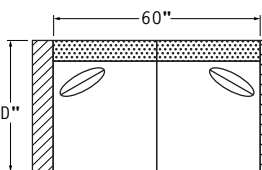

**#22**  
**60" SMALL SOFA**  
60" + ARMS

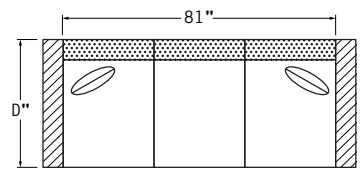

**#30**  
**81" SOFA**  
81" + ARMS

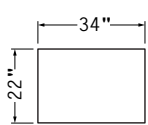

**#00**  
**OTTOMAN**  
34"

## RIGHT ARM

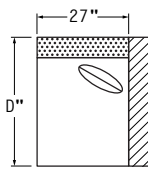

**#71**  
**RIGHT ARM FACING/  
LEFT SIDE ARMLESS**  
27" + ARM

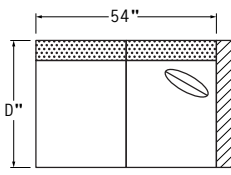

**#72**  
**RIGHT ARM FACING/  
LEFT SIDE ARMLESS**  
54" + ARM

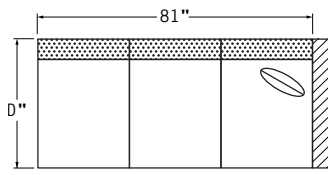

**#73**  
**RIGHT ARM FACING/  
LEFT SIDE ARMLESS**  
81" + ARM

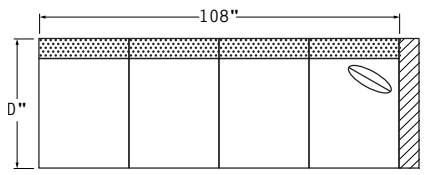

**#94**  
**RIGHT ARM FACING/  
LEFT SIDE ARMLESS**  
108" + ARM

## LEFT ARM

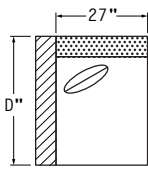

**#61**  
**LEFT ARM FACING/  
RIGHT SIDE ARMLESS**  
27" + ARM

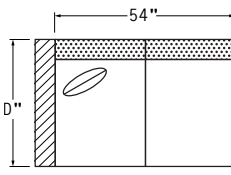

**#62**  
**LEFT ARM FACING/  
RIGHT SIDE ARMLESS**  
54" + ARM

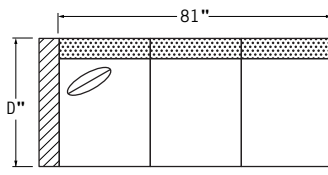

**#63**  
**LEFT ARM FACING/  
RIGHT SIDE ARMLESS**  
81" + ARM

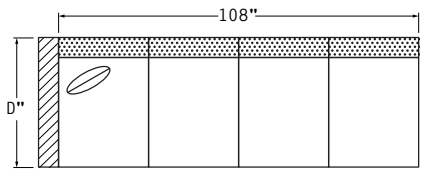

**#84**  
**LEFT ARM FACING/  
RIGHT SIDE ARMLESS**  
108" + ARM

## ARMLESS

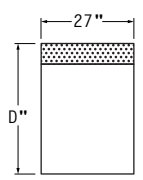

**#81**  
**1-CUSHION  
ARMLESS**  
27"

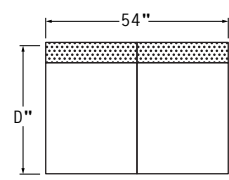

**#82**  
**2-CUSHION  
ARMLESS**  
54"

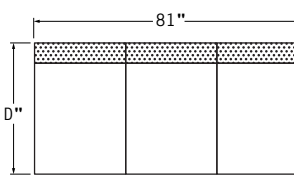

**#53**  
**3-CUSHION  
ARMLESS**  
81"

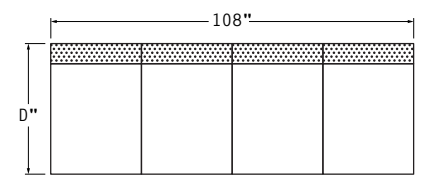

**#04**  
**4-CUSHION  
ARMLESS**  
108"

Images are not to scale.

**CORNER/RIGHT ARM**

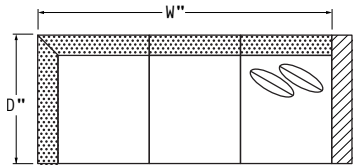

#33  
RIGHT ARM FACING/  
LEFT SIDE CORNER  
89''/91''/93'' + ARM

**CORNER/LEFT ARM**

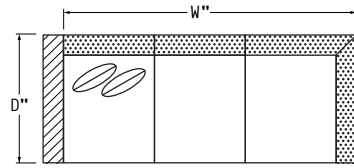

#23  
LEFT ARM FACING/  
RIGHT SIDE CORNER  
89''/91''/93'' + ARM

**CORNERS**

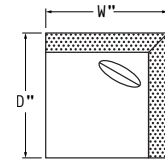

#41  
CORNER  
36''/38''/40''

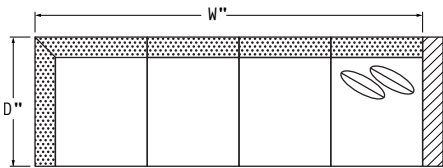

#34  
RIGHT ARM FACING/  
LEFT SIDE CORNER  
116''/118''/120'' + ARM

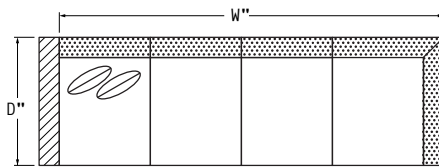

#24  
LEFT ARM FACING/  
RIGHT SIDE CORNER  
116''/118''/120'' + ARM

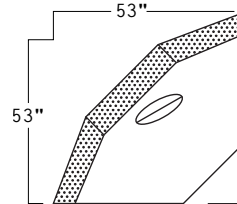

#87  
WEDGE CORNER  
53''

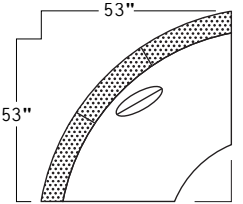

#86  
CURVE CORNER  
53''

**CHAISE/LEFT ARM**

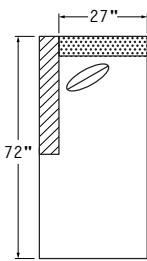

#74  
LEFT ARM FACING/  
RIGHT SIDE ARMLESS  
27'' + ARM

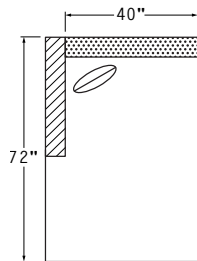

#76  
LEFT ARM FACING/  
RIGHT SIDE ARMLESS  
40'' + ARM

**CHAISE/RIGHT ARM**

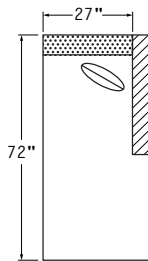

#64  
RIGHT ARM FACING/  
LEFT SIDE ARMLESS  
27'' + ARM

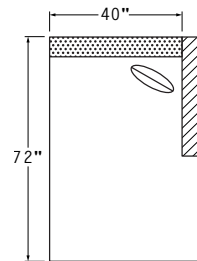

#66  
RIGHT ARM FACING/  
LEFT SIDE ARMLESS  
40'' + ARM

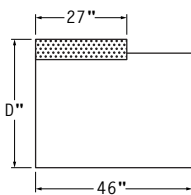

#65  
LEFT BUMPER  
46''

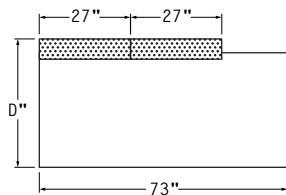

#67  
LEFT BUMPER  
73''

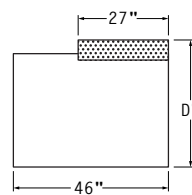

#75  
RIGHT BUMPER  
46''

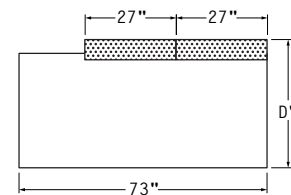

#77  
RIGHT BUMPER  
73''

**CORNERS/ARMS**

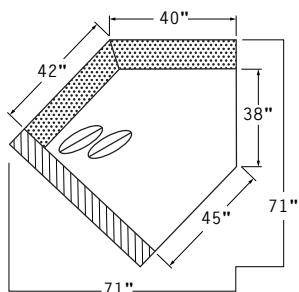

#68  
LEFT ARM FACING POD  
71''

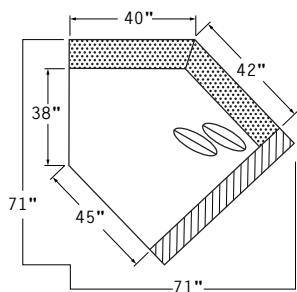

#78  
RIGHT ARM FACING POD  
71''

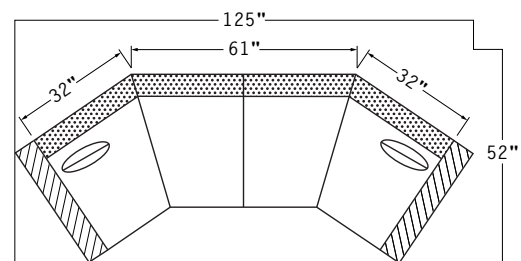

#85  
ANGLE SOFA  
125''

NOTES



BURTON JAMES

[burtonjames.com](http://burtonjames.com) · 626 961 7221 · [info@burtonjames.com](mailto:info@burtonjames.com)