

BURTON JAMES

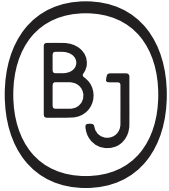

ALTERNATIVES

PERFECT COMFORT FOR EVERY STYLE



PERFECTLY STYLISH,
PERFECTLY COMFORTABLE,
PERFECTLY
YOU

Our **ALTERNATIVES** program, widely acclaimed as our most popular program among designers, distinguishes itself by offering the widest array of configurations, along with the option to select your depth and height.

Featuring a selection of arm styles, base and leg options, and back and seat cushion styles, **ALTERNATIVES** offers you the ability to create the spaces you dream of.

For questions, more information, or to request a custom quote, contact your sales representative or visit BURTONJAMES.COM.



STANDARD FEATURES

- Cloud 9 Seat Cushions
- Blend Down Back Cushions
- 8 Gauge Sinuous Springs
- Solid Kiln-Dried Wood Frame
- 20×20 Throw Pillows Included with Most Configurations
- All Pieces Available In:
 - Overall Depths: 36", 38", and 40"
 - Overall Back Heights: 34", 36", and 38"
 - Seat Cushions: 27"W
 - #10 Chair Cushion is 23"W
 - #22 Small Sofa Cushion is 30"W

STEP 1: CHOOSE YOUR STYLE, DEPTH, AND HEIGHT

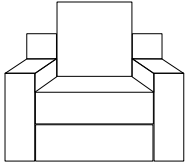
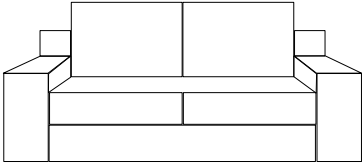
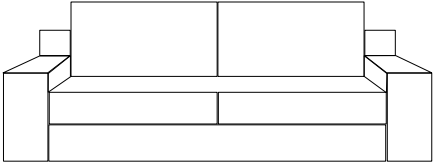
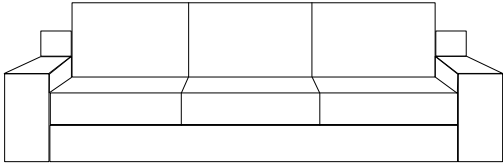
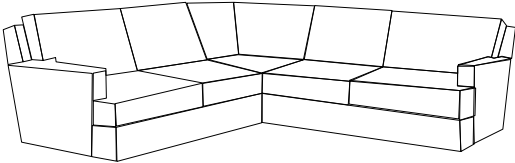
STYLE	OVERALL DEPTH	OVERALL HEIGHT
 <p><input type="checkbox"/> #10 - 23" Chair + Arms <input type="checkbox"/> Swivel Base (Upcharge)</p>	<input type="checkbox"/> 36" (20" Seat Depth) <input type="checkbox"/> 38" (22" Seat Depth) <input type="checkbox"/> 40" (24" Seat Depth)	<input type="checkbox"/> 34" <input type="checkbox"/> 36" <input type="checkbox"/> 38"
 <p><input type="checkbox"/> #20 - 54" Loveseat + Arms</p>	<input type="checkbox"/> 36" (20" Seat Depth) <input type="checkbox"/> 38" (22" Seat Depth) <input type="checkbox"/> 40" (24" Seat Depth)	<input type="checkbox"/> 34" <input type="checkbox"/> 36" <input type="checkbox"/> 38"
 <p><input type="checkbox"/> #22 - 60" Small Sofa + Arms</p>	<input type="checkbox"/> 36" (20" Seat Depth) <input type="checkbox"/> 38" (22" Seat Depth) <input type="checkbox"/> 40" (24" Seat Depth)	<input type="checkbox"/> 34" <input type="checkbox"/> 36" <input type="checkbox"/> 38"
 <p><input type="checkbox"/> #30 - 81" Sofa + Arms</p>	<input type="checkbox"/> 36" (20" Seat Depth) <input type="checkbox"/> 38" (22" Seat Depth) <input type="checkbox"/> 40" (24" Seat Depth)	<input type="checkbox"/> 34" <input type="checkbox"/> 36" <input type="checkbox"/> 38"
 <p><input type="checkbox"/> Sectional</p>	<div style="border: 1px solid black; padding: 10px; display: inline-block;"> <p>SELECT SECTIONAL PIECES AT STEP 8.</p> </div>	

STEP 2: CHOOSE YOUR ARM

Select welting options at step 7. Contrast welting subject to upcharge.

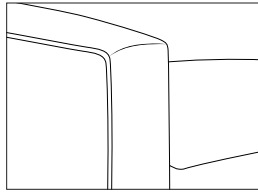

4" Track Arm

24"H

NO WELT

WELTING

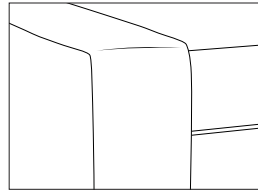

6" Track Arm

24"H

NO WELT

WELTING

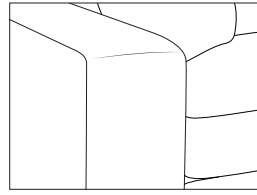

9" Track Arm

24"H

NO WELT

WELTING

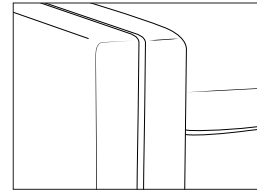

6" Split Track

26"H

INCLUDES 1/4" STANDARD WELT

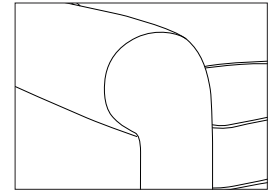

8" Sock Arm

26"H

NO WELT

WELTING

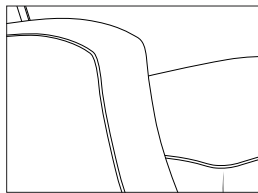

4.5" Deco Arm

24"H

NO WELT

WELTING

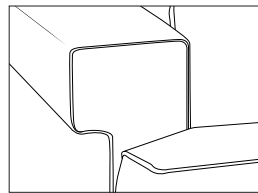

6" Grand Arm

24"H

NO WELT

WELTING

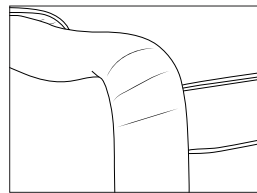

6" English Arm

26"H

NO WELT

WELTING

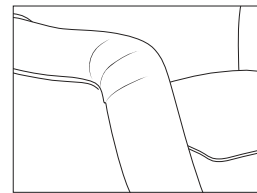

6" Bentley Arm

24"H

NO WELT

WELTING

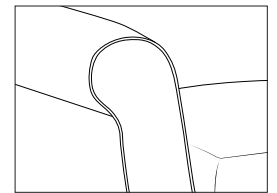

6" Dorset Arm

24"H

NO WELT

WELTING

STEP 3: CHOOSE YOUR BASE

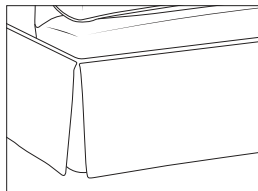

T-Flounce
Hidden Leg*

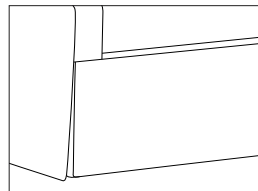

S-Flounce
Hidden Leg*

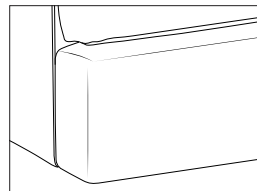

Plain
Hidden Leg*

Plain
Exposed Leg**

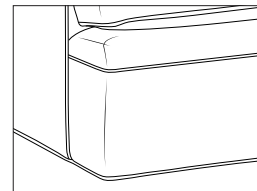

Banded
Hidden Leg*

Banded
Exposed Leg**

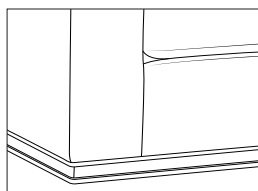

Molded Wood Base

UPCHARGE

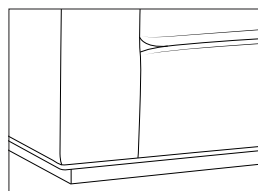

Recessed Wood Plinth Base

UPCHARGE

*Hidden leg finish is Caramel.

**Choose leg and wood finish at step 7. Base is shortened proportionally to exposed leg height.

STEP 4: CHOOSE YOUR SEAT SHAPE & SEAT FILL

Select welting options at step 7. Contrast welting subject to upcharge.

SEAT SHAPE

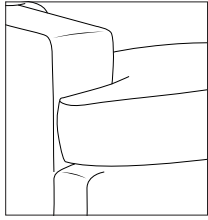

T-Cushion

NO WELT

WELTING

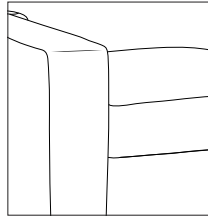

Square Cushion

NO WELT

WELTING

SEAT FILL

Cloud 9 (Standard Fill)

High density foam core, wrapped in two layers of polyester fiber for softness and bounce, encased in ticking for strength and durability. This is our most popular seat cushion.

Luxe Aire (No Additional Charge)

Premium polyurethane foam wrapped in D91 polyester fiber and encased in ticking. This is a firm seat with minimum crown ensuring comfort and durability.

Down Supreme (Upcharge)

High density foam interior encased in a 100% cotton down proof ticking envelope, of 90% feather and 10% down.

Spring Down (Upcharge)

High density foam interior surrounding a spring system, encased in a 100% cotton down proof ticking envelope, of 90% feather and 10% down.

Trillum (Upcharge)

High density foam core, encased in a 100% blown polyester fiber filled 100% cotton, channeled down proof cover. This option creates a very plush cushion that has a down like quality.



STEP 5: CHOOSE YOUR BACK SHAPE & BACK FILL

Select welting options at step 7. Contrast welting subject to upcharge.

BACK SHAPE

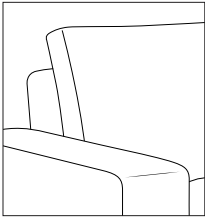

Square Boxed

NO WELT

WELTING

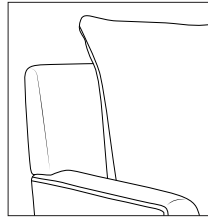

Knife Edge

NO WELT

WELTING

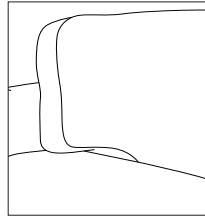

T-Boxed

NO WELT

WELTING

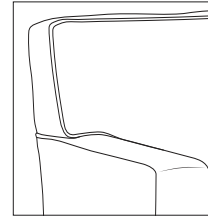

Tight Boxed

NO WELT

WELTING

BACK FILL

Blend Down (Standard Fill)

50% blown poly fiber, 45% feather, and 5% down channeled in a 100% cotton down proof ticking. This is our most popular back cushion.

Regalaire (No Additional Charge)

Polyester fiber channeled inside a nonwoven casing. This choice offers a firm but soft back cushion that requires some fluffing.

Down Supreme (Upcharge)

90% feather, 10% down channeled in a 100% cotton down proof ticking.

Trillium (Upcharge)

100% blown polyester fiber encased in a 100% cotton, channeled down proof cover. This soft, plush back cushion has a down like quality.

STEP 6: CHOOSE YOUR FABRIC

Any fabric from our Burton James collection, or COM, can be used. Refer to price list for pricing.

PATTERN: _____

COLOR: _____

STEP 7: ADD YOUR FINISHING TOUCHES

Select additional options: exposed legs, wood leg/base finish, nailheads, and welting.

EXPOSED LEG SHOWN IN CARAMEL

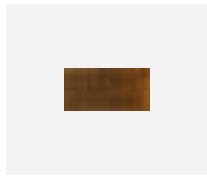

A - Wood
5"W x 2"H



B - Wood
6.5"W x 2"H



D - Wood
5.75"W x 3"H



E - Wood
5.75"W x 3"H



F - Wood
6"W x 3"H



H - Wood
2.75"W x 3.5"H



J - Wood
3"W x 6"H



L - Wood
3"W x 6"H



K - Acrylic
3.5"W x 5.5"H

UPCHARGE

CASTERS

- None Hidden

WOOD LEG AND BASE FINISH PICK ONE | HIDDEN LEG FINISH IS CARAMEL

Standard Wood Finishes



CREAM



MILK



CLOUD



NATURAL



SANDALWOOD



CARAMEL



FRENCH
WALNUT



OLD OAK



UMBER



DRIFTWOOD



SHADOW



BLACK WALNUT

Premium Wood Finishes UPCHARGE



LINEN



PEARL



SAND



ASH

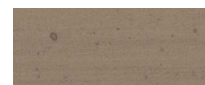

PUTTY



SLATE



SHALE



CAVALIER

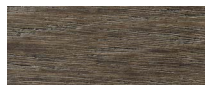

RUSTIC GRAY



REGENT



ZEBRA



BLACK
LACQUER

NAILHEADS UPCHARGE | STANDARD DOES NOT INCLUDE NAILHEADS

Nailhead Size SHOWN TO SCALE | PICK ONE

- None
 Small: 7/16"
 Medium: 5/8"
 Large: 1"

Nailhead Finish 7/16" SHOWN | PICK ONE

- FRENCH NATURAL
 PEWTER
 NICKEL
 BRIGHT GOLD
 ANTIQUE BRASS
 BLACK PEARL
 BRONZE

Nailhead Spacing

- HEAD-TO-HEAD
 

 ONE ON, ONE OFF
 

Nailhead Location

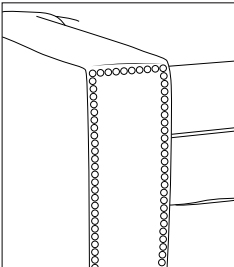
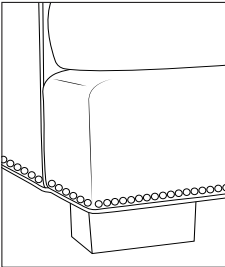
- ARMS
 BODY/BASE
- 
- 

WELTING

Welt Location + Type

ARM

- NONE
 1/4" SELF WELT
 1/8" SELF WELT
 1/4" CONTRAST WELT **UPCHARGE**
 1/8" CONTRAST WELT **UPCHARGE**

BODY

- NONE
 1/4" SELF WELT
 1/8" SELF WELT
 1/4" CONTRAST WELT **UPCHARGE**
 1/8" CONTRAST WELT **UPCHARGE**

SEAT/BACK CUSHION

- NONE
 1/4" SELF WELT
 1/8" SELF WELT
 1/4" CONTRAST WELT **UPCHARGE**
 1/8" CONTRAST WELT **UPCHARGE**

CONTRAST WELT FABRIC PATTERN: _____

CONTRAST WELT FABRIC COLOR: _____

Images are representations only. For true match please refer to physical samples.
 Premium finishes, nailheads & acrylic leg(s) subject to additional charge.

STEP 8: CHOOSE YOUR SECTIONAL PIECES

OVERALL DEPTH

- 36" (20" Seat Depth)
- 38" (22" Seat Depth)
- 40" (24" Seat Depth)

OVERALL HEIGHT

- 34"
- 36"
- 38"

KEY:  ARMS  BACK  THROW PILLOW

SOFAS/CHAIR

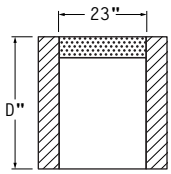

#10
CHAIR
23" + ARMS

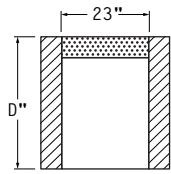

#11
SWIVEL CHAIR
23" + ARMS

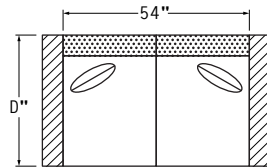

#20
54" LOVESEAT
54" + ARMS

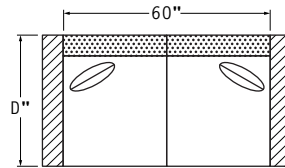

#22
60" SMALL SOFA
60" + ARMS

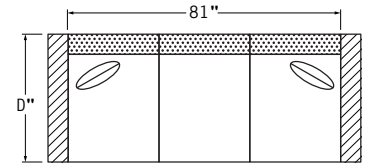

#30
81" SOFA
81" + ARMS

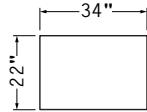

#00
OTTOMAN
34"

RIGHT ARM

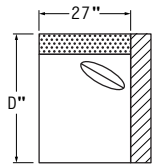

#71
RIGHT ARM FACING/
LEFT SIDE ARMLESS
27" + ARM

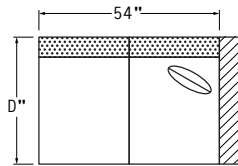

#72
RIGHT ARM FACING/
LEFT SIDE ARMLESS
54" + ARM

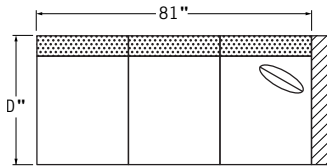

#73
RIGHT ARM FACING/
LEFT SIDE ARMLESS
81" + ARM

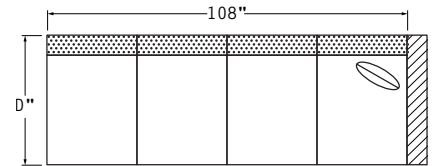

#94
RIGHT ARM FACING/
LEFT SIDE ARMLESS
108" + ARM

LEFT ARM

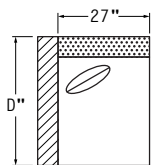

#61
LEFT ARM FACING/
RIGHT SIDE ARMLESS
27" + ARM

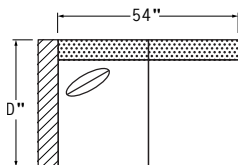

#62
LEFT ARM FACING/
RIGHT SIDE ARMLESS
54" + ARM

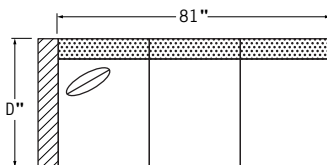

#63
LEFT ARM FACING/
RIGHT SIDE ARMLESS
81" + ARM

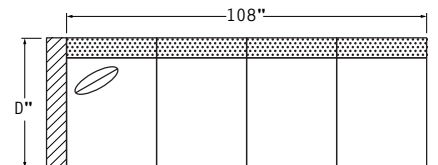

#84
LEFT ARM FACING/
RIGHT SIDE ARMLESS
108" + ARM

ARMLESS

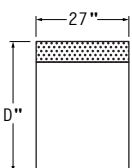

#81
1-CUSHION
ARMLESS
27"

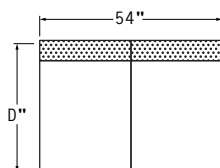

#82
2-CUSHION
ARMLESS
54"

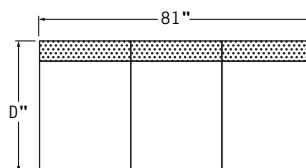

#53
3-CUSHION
ARMLESS
81"

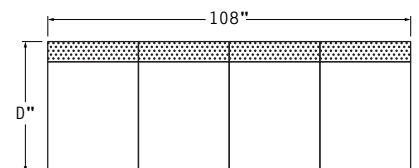

#04
4-CUSHION
ARMLESS
108"

CORNER/RIGHT ARM

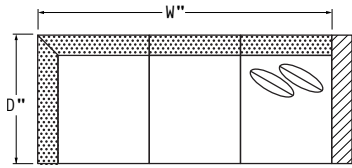

#33
RIGHT ARM FACING/
LEFT SIDE CORNER
89''/91''/93'' + ARM

CORNER/LEFT ARM

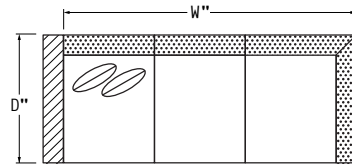

#23
LEFT ARM FACING/
RIGHT SIDE CORNER
89''/91''/93'' + ARM

CORNERS

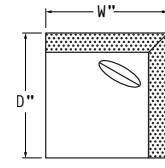

#41
CORNER
36''/38''/40''

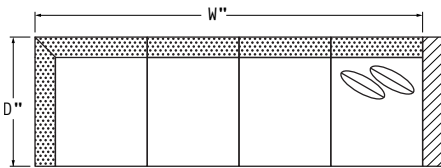

#34
RIGHT ARM FACING/
LEFT SIDE CORNER
116''/118''/120'' + ARM

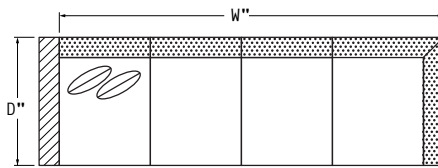

#24
LEFT ARM FACING/
RIGHT SIDE CORNER
116''/118''/120'' + ARM

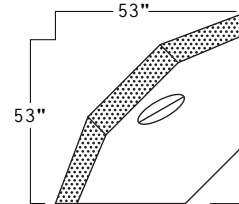

#87
WEDGE CORNER
53''

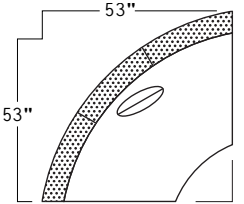

#86
CURVE CORNER
53''

CHAISE/LEFT ARM

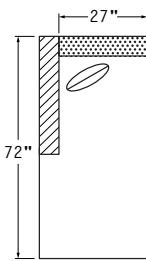

#74
LEFT ARM FACING/
RIGHT SIDE ARMLESS
27'' + ARM

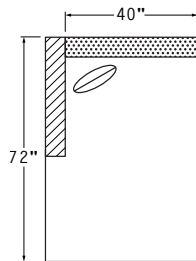

#76
LEFT ARM FACING/
RIGHT SIDE ARMLESS
40'' + ARM

CHAISE/RIGHT ARM

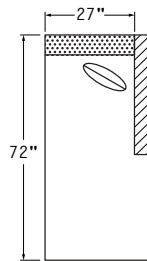

#64
RIGHT ARM FACING/
LEFT SIDE ARMLESS
27'' + ARM

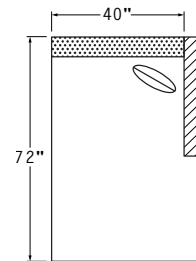

#66
RIGHT ARM FACING/
LEFT SIDE ARMLESS
40'' + ARM

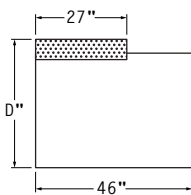

#65
LEFT BUMPER
46''

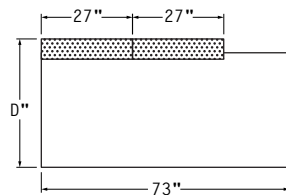

#67
LEFT BUMPER
73''

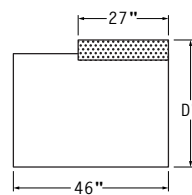

#75
RIGHT BUMPER
46''

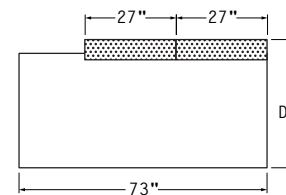

#77
RIGHT BUMPER
73''

CORNERS/ARMS

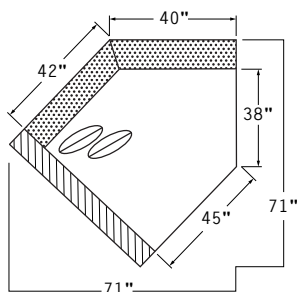

#68
LEFT ARM FACING POD
71''

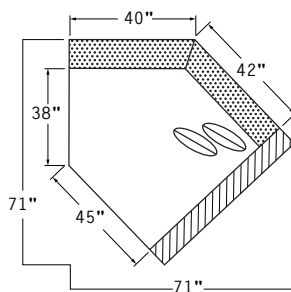

#78
RIGHT ARM FACING POD
71''

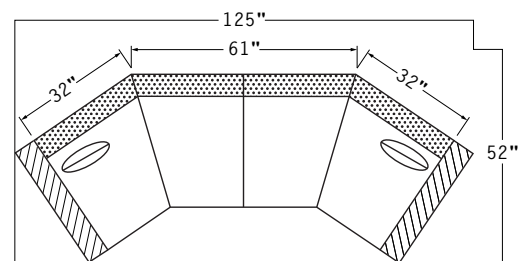

#85
ANGLE SOFA
125''

NOTES/DRAWING

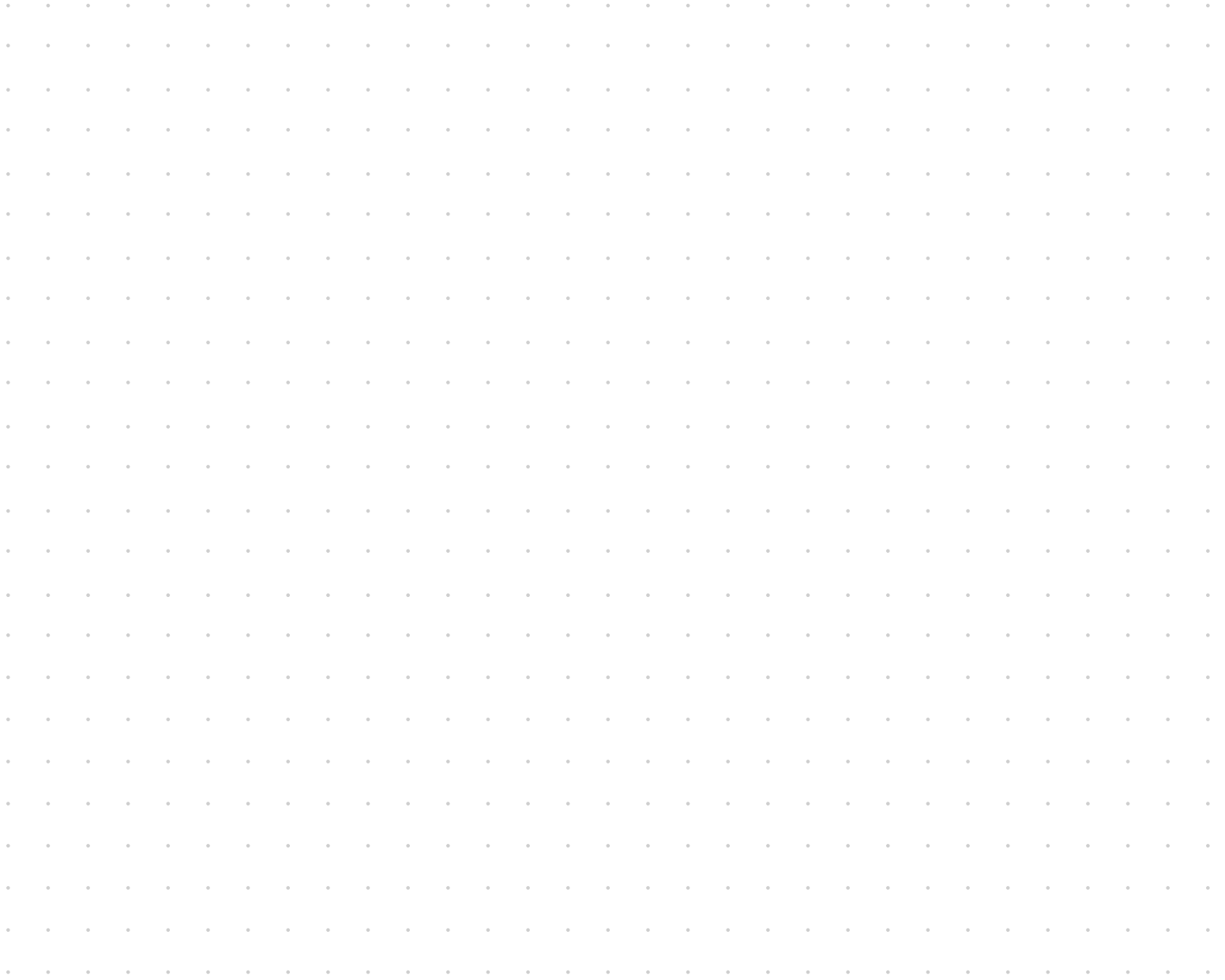

BURTON JAMES

burtonjames.com · 626 961 7221 · info@burtonjames.com