

BURTON JAMES



DESIGNER'S CHOICE

THE FULLY CUSTOMIZABLE SECTIONAL



DESIGN YOUR IDEAL SECTIONAL TAILORED TO YOUR EXACT NEEDS

Our Designer's Choice Program provides full customization in 8 simple steps. Tailor-make your sectional by handpicking from an array of fabrics, arm styles, base & back variations, wood finishes, nailhead embellishments, and custom seat preferences.

If you don't find the length and depth you need for your project, we can work with you to customize the perfect piece.

For questions, more information, or to request a custom quote, contact your sales representative or visit BURTONJAMES.COM.

STEP 1: CHOOSE A STYLE

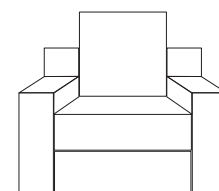

#10 - Chair
41"D x 24"W + ARMS

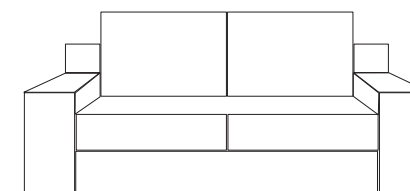

#20 - 60" Loveseat
41"D x 60"W + ARMS

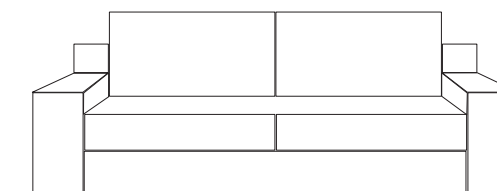

#30 - 76" Small Sofa + Arms
41"D x 76"W + ARMS

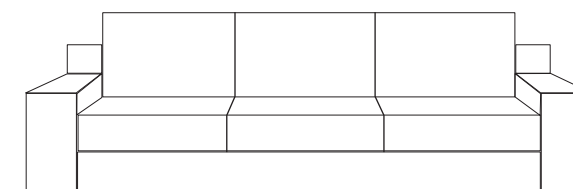

#40 - 90" Sofa + Arms
41"D x 90"L + ARMS

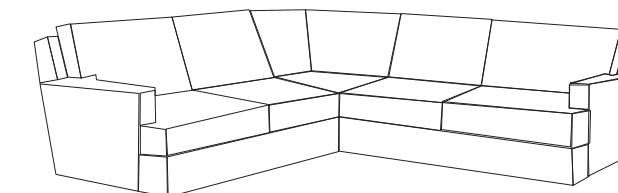

Sectional
Select configurations at step 8.

STEP 2: CHOOSE AN ARM

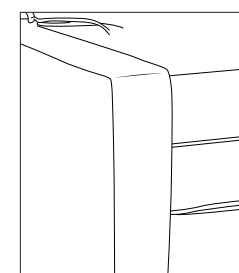

4" Track Arm
26"H

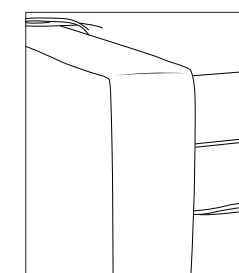

6" Track Arm
26"H

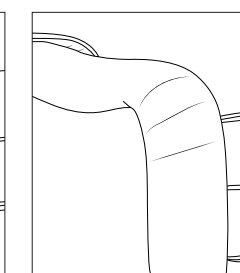

6" English Arm
25"H

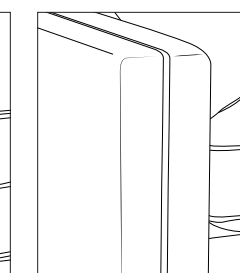

6" Split Track
26"H

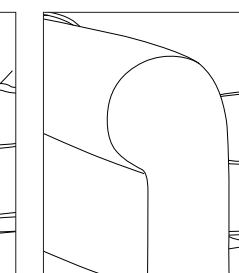

8" Sock Arm
26"H

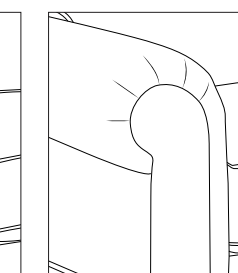

8" Panel Arm
26"H

STEP 3: CHOOSE A BASE

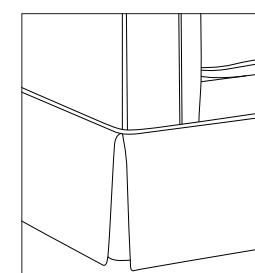

Dressmaker
Flounce
(Hidden Leg*)

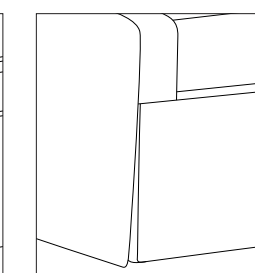

S-Flounce
(Hidden Leg*)

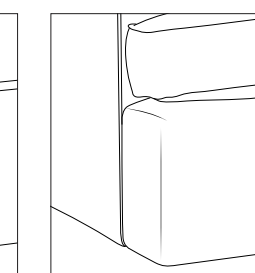

Plain
(Hidden Leg*)

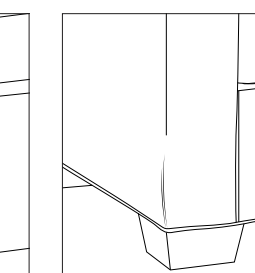

Tapered
Block Leg**

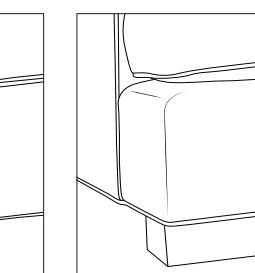

Block Leg**

*Hidden leg finish is Caramel.
**Choose wood finish at step 7.

STANDARD FEATURES

- Cloud 9 Seat Cushions
- Blend Down Back Cushions
- 8 Gauge Sinuous Springs
- Solid Kiln-Dried Wood Frame
- Standard Dimensions:
Depth: 41"
Height: 39"
Seat Depth: 24"
Seat Cushions*: 30"W
*#10 chair cushion is 24"W.
#30 sofa cushions are 38"W.

UPCHARGES

- Other Cushion Fills
- Nailheads
- Premium Wood Finishes
- Welting
- 8-Way Hand Tied Springs
- Custom Sizes Available:
Depth, Length, or Height

STEP 4: CHOOSE YOUR SEAT SHAPE & SEAT FILL

SEAT SHAPE

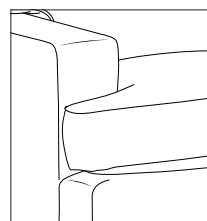

T-Cushion

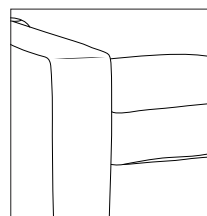

Square Cushion

SEAT FILL

- Cloud 9 (Standard Fill)**
High density foam core, wrapped in two layers of polyester fiber for softness and bounce, encased in ticking for strength and durability. This is our most popular seat cushion.
- Luxe Aire (Standard Fill)**
Premium polyurethane foam wrapped in D91 polyester fiber and encased in ticking. This is a firm seat with minimum crown ensuring comfort and durability.
- Down Supreme (Upcharge)**
High density foam interior encased in a 100% cotton down proof ticking envelope, of 90% feather and 10% down.
- Spring Down (Upcharge)**
High density foam interior surrounding a spring system, encased in a 100% cotton down proof ticking envelope, of 90% feather and 10% down.
- Trillum (Upcharge)**
High density foam core, encased in a 100% blown polyester fiber filled 100% cotton, channeled down proof cover. This option creates a very plush cushion that has a down like quality.

STEP 5: CHOOSE YOUR BACK SHAPE & BACK FILL

BACK SHAPE

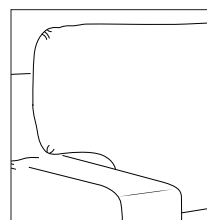

T-Knife Edge

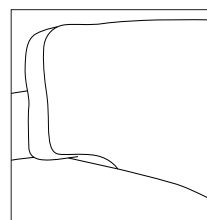

T-Boxed

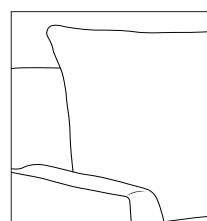

Square Knife Edge

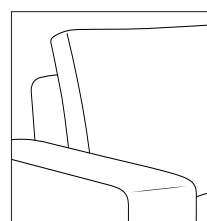

Square Boxed

BACK FILL

- Blend Down (Standard Fill)**
50% blown poly fiber, 45% feather, and 5% down channeled in a 100% cotton down proof ticking. This is our most popular back cushion.
- Regalaire (Standard Fill)**
Polyester fiber channeled inside a nonwoven casing. This choice offers a firm but soft back cushion that requires some fluffing.
- Down Supreme (Upcharge)**
90% feather, 10% down channeled in a 100% cotton down proof ticking.
- Trillum (Upcharge)**
100% blown polyester fiber encased in a 100% cotton, channeled down proof cover. This soft, plush back cushion has a down like quality.

STEP 6: CHOOSE YOUR FABRIC

Any fabric from our Burton James collection can be used. Refer to price list for pricing.

PATTERN: _____

COLOR: _____

STEP 7: ADD YOUR FINISHING TOUCHES

Select your wood leg finish, nailheads, and welting.

WOOD LEG FINISHES PICK ONE | HIDDEN LEG DEFAULT FINISH: CARAMEL

Standard Wood Finishes

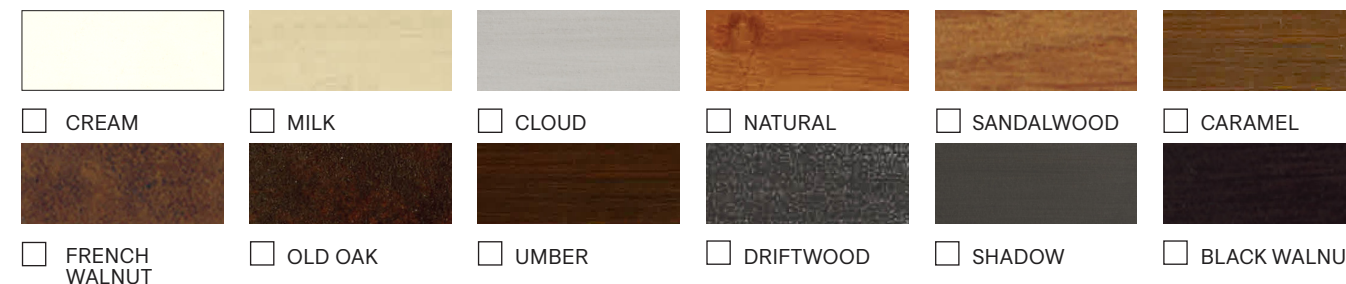

Premium Wood Finishes UPCHARGE



NAILHEADS UPCHARGE | STANDARD DOES NOT INCLUDE NAILHEADS

Nailhead Size SHOWN TO SCALE | PICK ONE

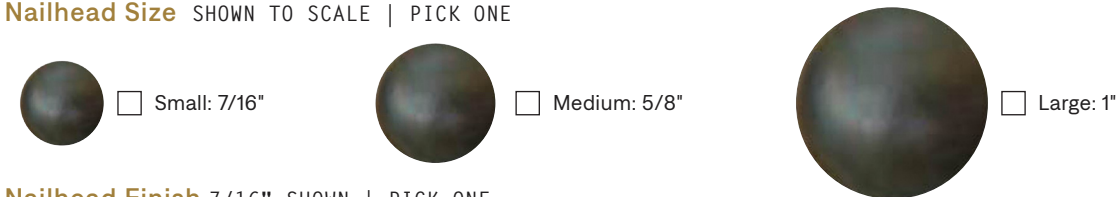

Nailhead Finish 7/16" SHOWN | PICK ONE

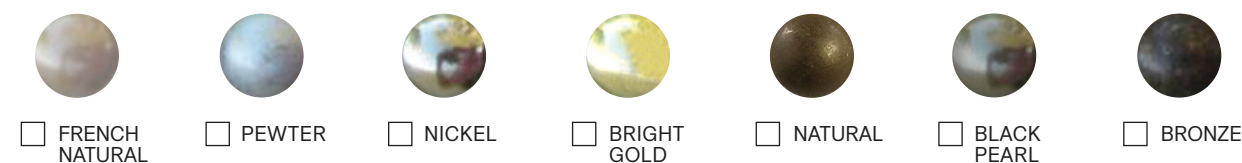

Nailhead Spacing

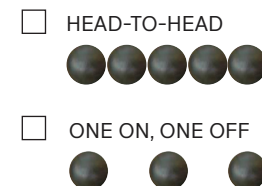

Nailhead Location

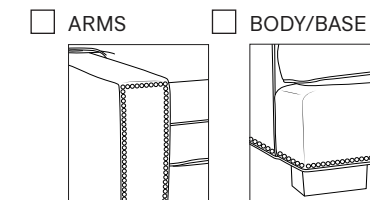

WELTING UPCHARGE | STANDARD DOES NOT INCLUDE WELTING

Welt Type + Location

- 1/4" SELF-WELT (UPCHARGE) 1/4" CONTRAST WELT (UPCHARGE)
- SEAT/BACK CUSHION SEAT/BACK CUSHION FRAME FRAME
- FABRIC PATTERN: _____
- COLOR: _____

Images are representations only. For true match please refer to physical samples.

STEP 8: CHOOSE YOUR SECTIONAL PIECES

CREATE THE PERFECT CONFIGURATION FOR YOUR DESIGN NEEDS FROM OVER 20 OPTIONS.

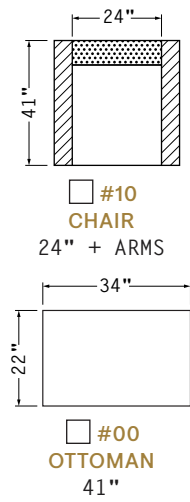

SOFAS/CHAIR

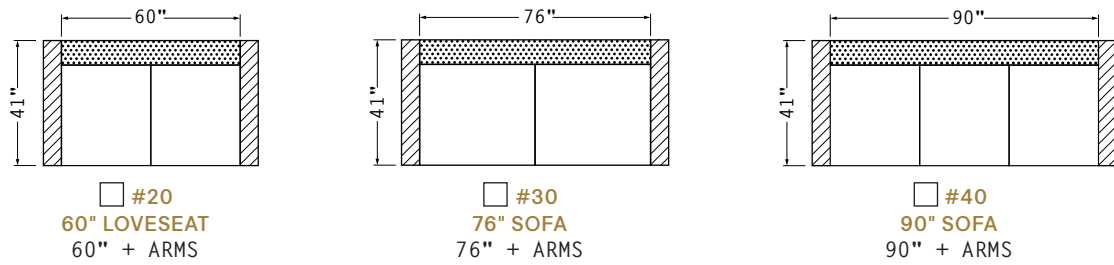

RIGHT ARM

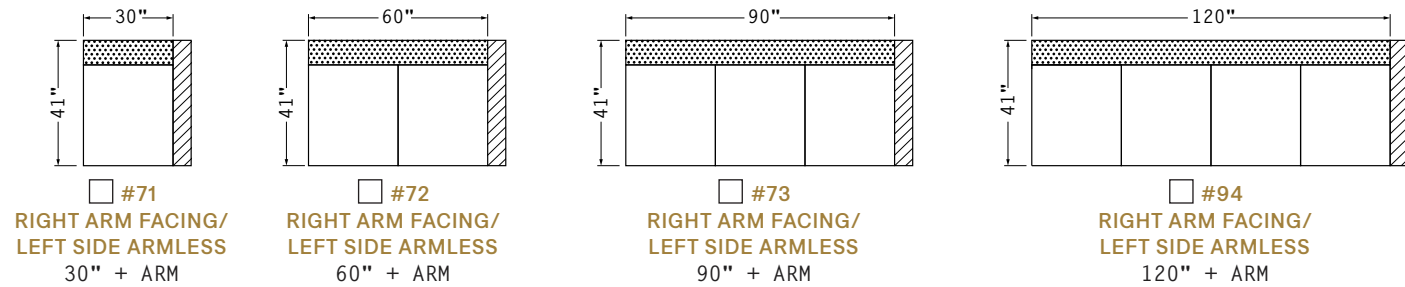

LEFT ARM

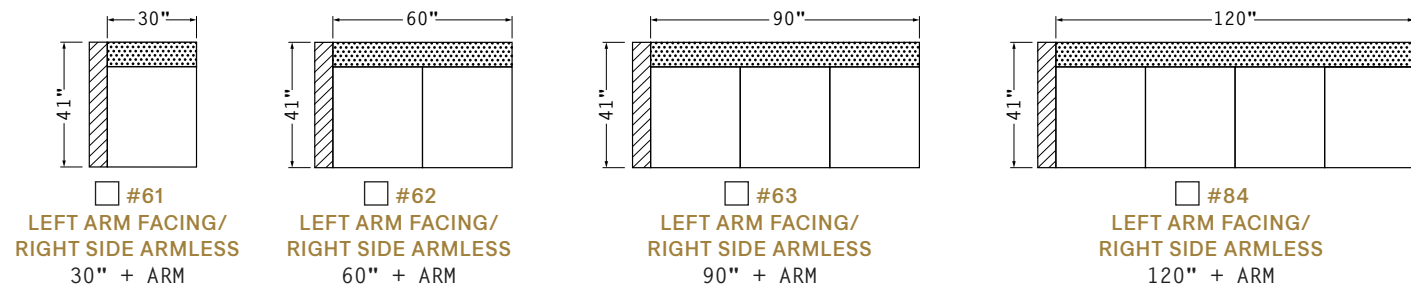

ARMLESS

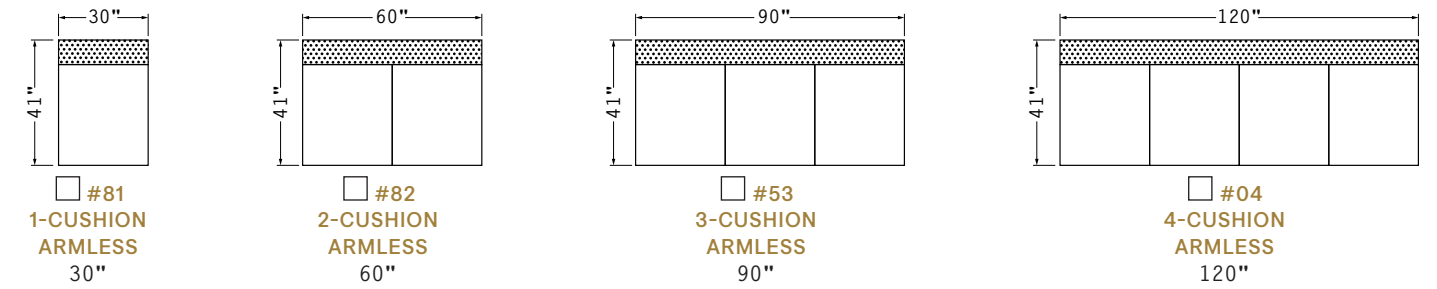

CORNER/RIGHT ARM

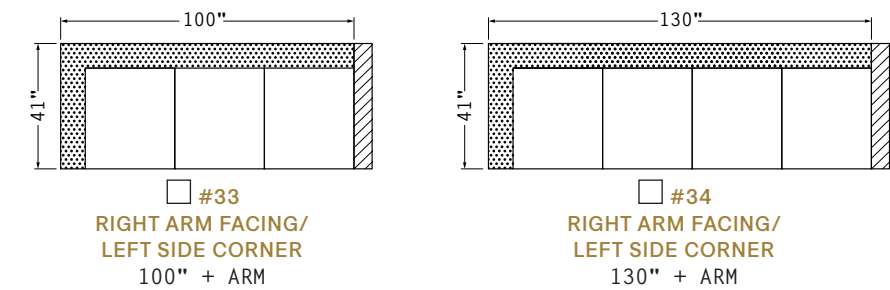

CORNER/LEFT ARM

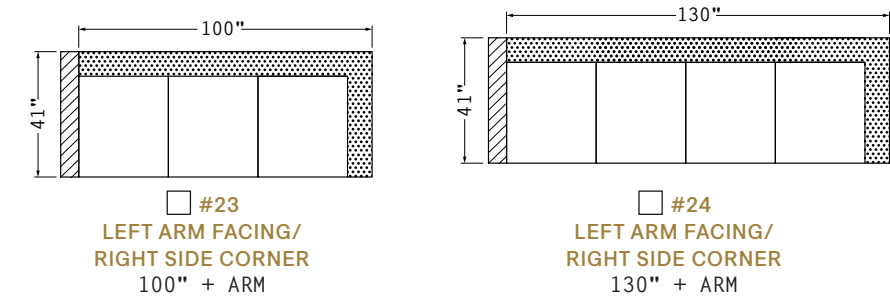

CORNER

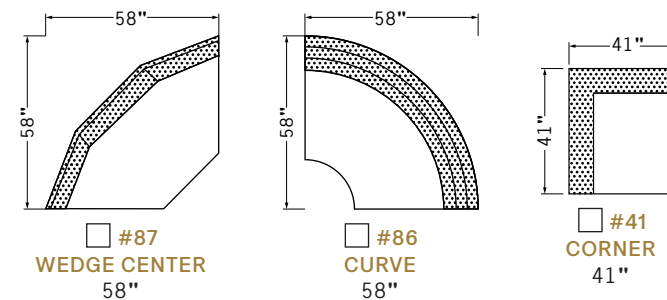

CHAISE

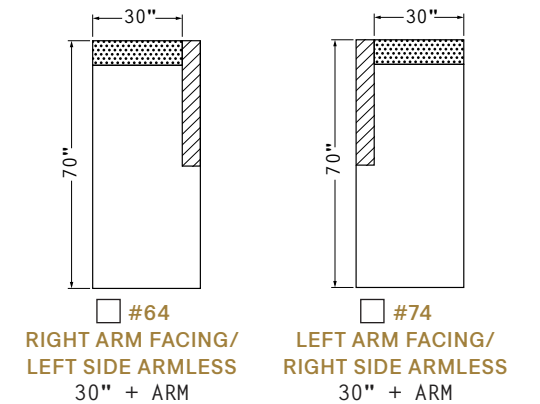

NOTES

